



SCOTNET SOLUTIONS



SCOTNET SOLUTIONS 33 CARRON PLACE EAST KILBRIDE GLASGOW G75 0QB SCOTLAND

T: +44 (0) 1355 244 244 F: +44 (0) 1355 266 655 E: INFO@SCOTNET SOLUTIONS.COM W: WWW.SCOTNETSOLUTIONS.COM

Stuffing Equipment: Automatic

Output: 700 - 1200 Units per hour
Ideal Netting Volume: 1000 - 5000m per day

DS1200P₃ - High Speed Double Stuffer

1 Optional Information Screen controlling machine functions and reporting output and efficiency figures



2 Braked Castors ensuring secure footing while working, and easy movement when required



3 E-Stops mounted on both sides

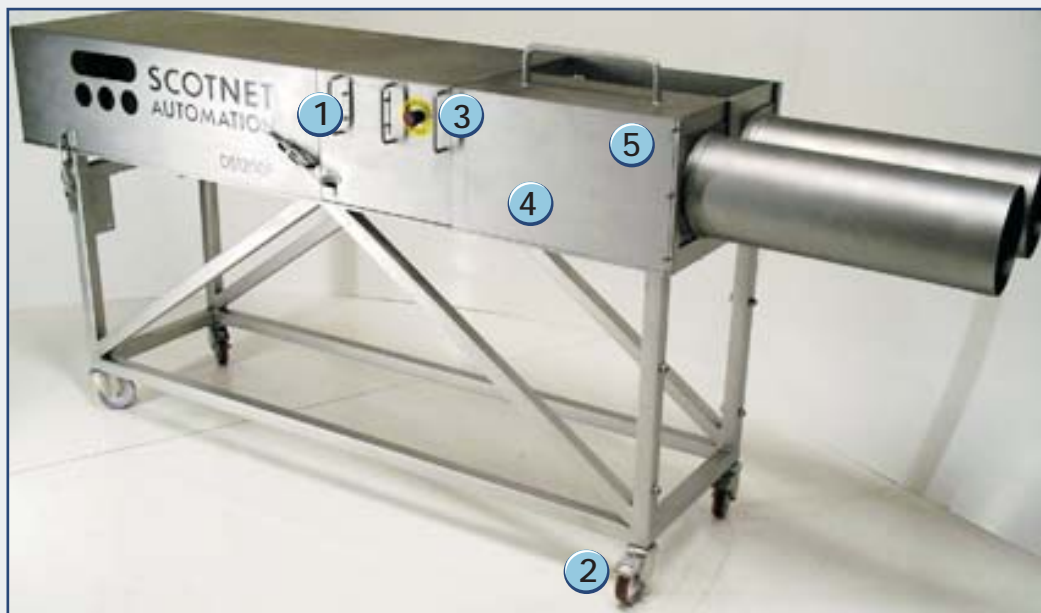

4 Chambers compartments open at base for easy cleaning



5 Simple tool-less chamber size change



Options:

AWI: Injects a fine spray of water into each chamber each cycle, to ease movement of dry products, such as pork.

VSL: Allows shortening of piston strokes, to optimise shape.

Information Screen: See detail 1

Can be used with our Casing Tubes, or our Netting Tubes

Available in all sizes from 75mm to 200mm

All manufactured from 316 Stainless Steel - safe for food contact

 Compliant with the latest safety standards



SCOTNET SOLUTIONS 33 CARRON PLACE EAST KILBRIDE GLASGOW G75 0QB SCOTLAND

T: +44 (0) 1355 244 244 F: +44 (0) 1355 266 655 E: INFO@SCOTNET SOLUTIONS.COM W: WWW.SCOTNETSOLUTIONS.COM

Stuffing Equipment: Automatic

DS1200P₃ - High Speed Double Stuffer - Available Accessories

600mm
Netting Tubes



1



Fully welded joints,
removing bug traps

Our tubes are
600mm long,
allowing between 1½
and 2 x as much
net to be loaded,
reducing waste and
changeovers

P₃ Chambers



Fully welded joints,
removing bug traps



Integrated
handle for easy
removal



All the accessories
are permanently
marked with their
size, for easy
identification

P₃ Pistons



The pistons are
made from solid
food grade
nylon, and are
drilled to prevent
suction on the
return strokes

Available in all sizes from 75mm to 200mm

All manufactured from 316 Stainless Steel - safe for food contact

 Compliant with the latest
safety standards



SCOTNET SOLUTIONS 33 CARRON PLACE EAST KILBRIDE GLASGOW G75 0QB SCOTLAND

T: +44 (0) 1355 244 244 F: +44 (0) 1355 266 655 E: INFO@SCOTNET SOLUTIONS.COM W: WWW.SCOTNETSOLUTIONS.COM

Stuffing Equipment: Automatic

Technical Information

DS1200P₃ - High Speed Double Stuffer / DS1200P₃C /DS Stripper

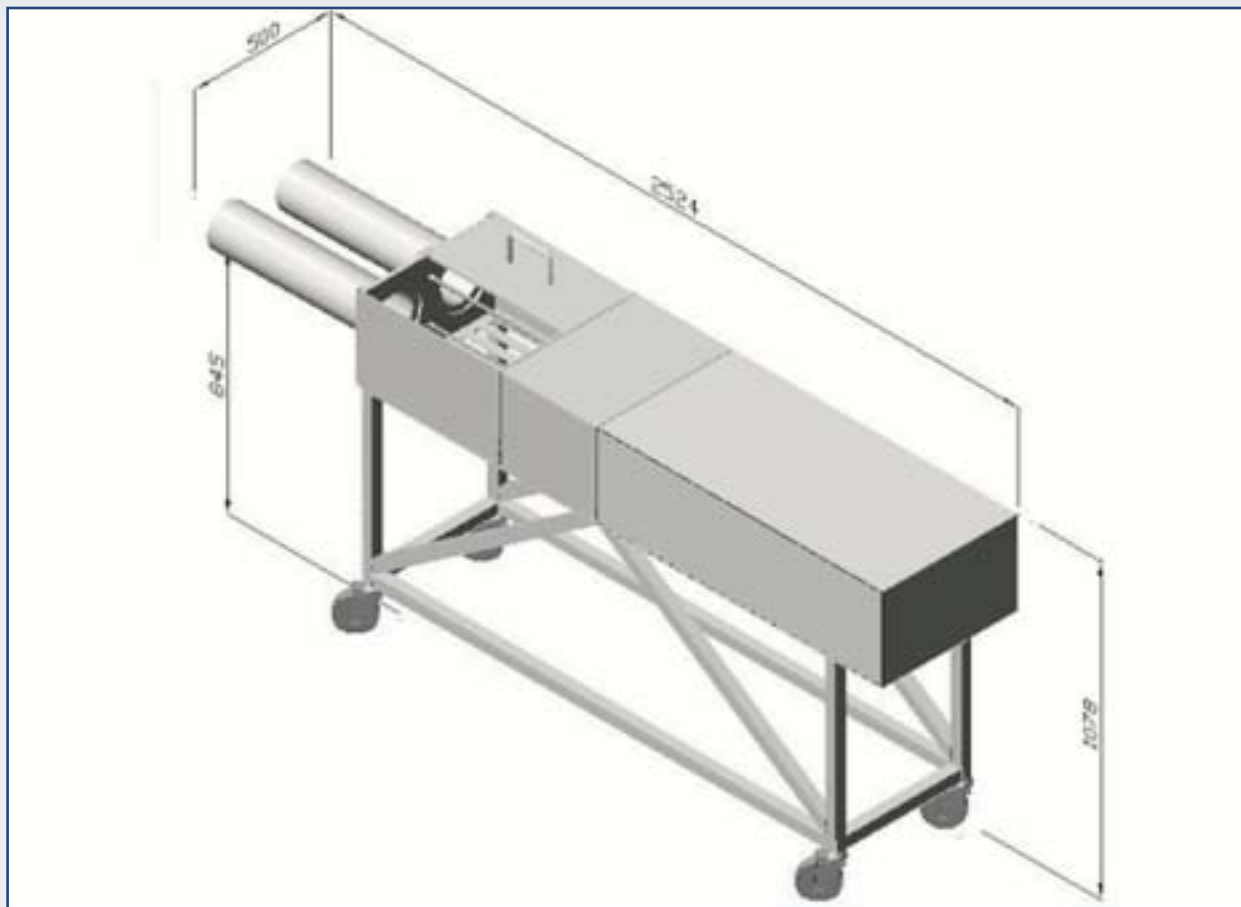

Speed:

The machine will cycle at over 1200 units per hour. Production speeds will depend on the product, and the input and output flow to the machine

Weight:

200 kg approx

Packing Case Dimensions: L X B X H

2090mm x 1435mm x 940mm

Services:

Compressed Air:
80psi or 5.5 BAR
46ft³ or 1320 litres per minute

Electrical:

230 V, Single phase, 5 amp supply

